



## 1 - Installation

Depending on the model, safe could be wall-mounted or installed on a plane surface. For the first type of installation, it is necessary to install the safe in a suitable place that is a wall not particularly humid and placed in a moisture condensation free room. After having checked the correct working of all safe components (see points 2 - 6) follow the instructions below:

1. Make a hole into the wall. To ensure perfect hold it should have following features:
  - Optimal Depth: the safe door should be perfectly aligned to the wall (see Fig. 1).
  - A free space of 5÷10 cm. on all the 4 sides for filling with cement.
 Empty spaces inside the wall should be filled with bricks until a plane and stable surface for the safe has been built. Furthermore, for a better pull-resistance it is recommended to insert steel rebars into the folded fins on the back.
2. Protect the front of the safe with transparent plastic film fixed with adhesive tape or similar.
3. Fix the safe into the hole after checking the correct position i.e. door hinges are positioned on right-hand side when you face it and the installing surface is plane (see Fig. 1).
 

**Never turn the safe upside down: in that case, Viro is not responsible for any working defects of the safe.**
4. Wall the safe with mixed 425 cement and sand in proportion 400 kg/m<sup>3</sup>.
 

N.B. : to further increase the resistance to attack it is recommended to wrap the safe with electro welded net before walling it.
5. **After the installation and in order to avoid condensation inside the safe, it is recommended to leave the door open for a couple of days.**

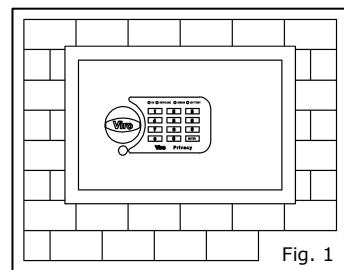

Fig. 1

Free standing safes can be wall mounted by using dowels, fixed on a plane surface, for example into a piece of furniture (see Fig. 2) or wall mounted using anchoring kit (item 4500.0758). **N.B. : for free standing safe wall installation it is necessary to follow same instructions as per wall safes.**

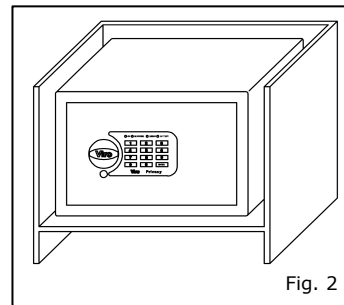

Fig. 2

## 2 - Insert / Replace batteries

1. Open the safe and take the battery case out of its housing by simply removing the plastic top that covers it (see Fig. 3).
2. Remove the battery box.
3. Remove the batteries (in case of replacement).
4. Insert new batteries **paying attention to the polarity** indicated on the battery case: make sure you hear a beep.
5. Place the battery case back into its housing and put back its cover.

**ATTENTION:** Use only AA LR6 type 1,5V alkaline batteries. All 4 batteries of the same safe must be replaced at once. Do not use together new and old batteries or batteries of a different type and quality. **When the batteries are almost empty each time you open there will be a blink of the "BATTERY" red LED (see Fig. 4): replace then the batteries.**

**N.B. : the electronic card has a non volatile memory so the memorized code is not erased when batteries are missing or replaced.**

## 3 - Code setting (min. 3 - max. 8 digits)

1. **With door opened** (retracted lockbolts) press and release "C" key on the keypad: "NEW CODE" green LED will light up (see Fig. 4).
2. Within 10 sec enter a personal code of min. 3 - max. 8 digits. (N.B. : if within 10 sec no code is entered, restart from point 1).
3. Press "ENTER" and make sure a quick triple beep is heard and the "OK" green LED blinks.
4. Within 5 sec, enter the personal code and press "ENTER" again. The green LED "OK" off and a sound will confirm the code is memorized.
 

**Do not forget your personal code. ATTENTION: Viro is not responsible for any inconvenience caused by an erroneous code setting or if code is forgotten.**

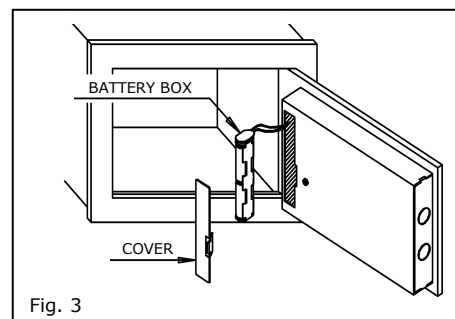

Fig. 3

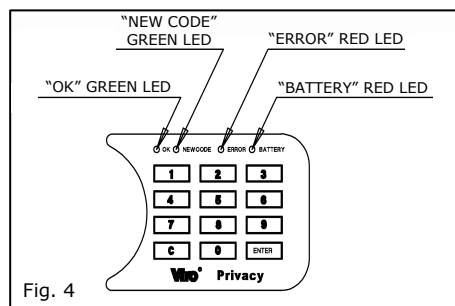

Fig. 4

## 4 - Closing

1. Remove the yellow cap (at first use).
2. Close the safe door manually.
3. Turn the knob counter clockwise.

## 5 - Opening

1. Enter the set opening code.
2. Press "ENTER".
3. Turn the knob clockwise within 5 sec.

**N.B. : the electronic safes Privacy are provided with an electronic anti theft 15 min block, after 5 consecutive attempts to open with wrong code respectively; during the block "OK" green LED blinks every 10 seconds and it is possible to open the safe only with the emergency mechanical key (see paragraph 6).**

## 6 - Emergency opening with mechanical key

The mechanical emergency key is supplied in a sealed envelope inside the packaging. It is always possible to open the safe with emergency key even in case the electronic card is damaged, when power supply is missing (low batteries) or in case of code forgotten. To open the safe with emergency key is necessary:

1. Remove the plastic top placed down the knob in order to access the key hub (see Fig. 5).
2. Insert the key and turn it clockwise till it stops. Turn the knob clockwise while keeping the key firm.

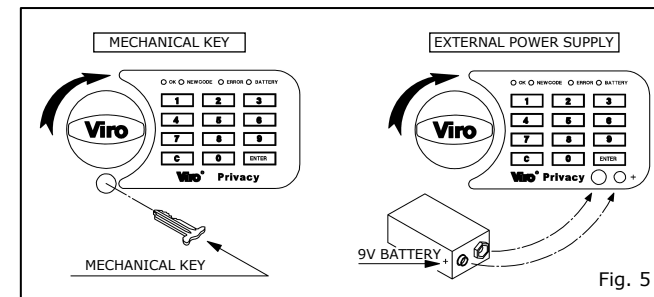

Fig. 5

Once the door is opened, remove the key and put back the key hub top. **Keep the present instructions and the emergency key in a secured place but never inside the safe itself.**

## 6 - Emergency opening with external power supply

In case there is no power supply (batteries empty) the safe may be opened with external power supply with a 9V battery. To open the safe with external power supply is necessary to:

1. Press the battery endings to the special connectors on the keypad (see Fig. 5) **paying attention to the polarity.**
2. Enter the opening code while keeping the battery pressed.
3. Press "ENTER".
4. Turn the knob clockwise within 5 sec.

Once the door is opened replace the batteries (see paragraph 2).

## 7 - Emergency key copy

**Emergency key can be duplicated only at our factory. When requesting duplicates from VIRO, please send a fax or an e-mail with a photo of the coded ownership card supplied in a sealed envelope.**

## Warranty conditions and contents

All Viro products undergo the most stringent testing and therefore guarantee reliability. Viro SpA reserves the right to introduce modifications or improvements to its products, which may deem desirable without obligating itself to install such improvements to its previously manufactured safes. Viro SpA guarantee their products to be free from defects in material and manufacturing for the period provided for by effective law on purchasing time (Directive No 1099/44/CE) and will replace or repair at no charge all component parts of the product under warranty - after consultation with our technical department or an authorised Service Centre - should they be defective due to a manufacturing or material flaw. The warranty covers the replacement of the components, ex-works, if defective, but does not include the safe opening costs, the removing costs and the final replacement, or any other cost or damage, even though related to the defective product. The property damage responsibility of Viro SpA will be in no case higher than the selling price of the article itself, even if the damage - including the content of the safe - is due to forcing, theft or burglary. The warranty shall not apply to any Viro component part which has been subject to misuse, neglect, incorrect installation of maintenance, or to a use in contravention of instructions furnished by the Company. The warranty does not extend to safes which have been installed in unsuitable environments or which have been repaired by unauthorised personnel or suffered damage in transit, or to any other circumstance not ascribable to faults in manufacture. Viro SpA shall not be liable for any direct, indirect and consequential damage and/or injury arising from the malfunctioning of their product or from the safes, or if caused by negligence or by lack of compliance with the instructions manual. The warranty shall take effect from the date of purchase. Sales receipt (fiscal receipt, cash-desk receipt, invoice, delivery note or the like) validates the date of purchase, irrespective of the actual fitting date. Failing a sales receipt, the warranty shall be calculated from the date of manufacture of the product, which shall be determined from its serial number. In case of purchasing of safe/cabinet supplied complete with external contacts for the emergency opening (without mechanical emergency opening), should the safe not be open due to its block or malfunctioning, Viro SpA is free from any responsibility for damages caused to things or persons, even if connected or depending to the malfunctioning, including the content of the safe. The Seller is completely excluded from any costs and charges for forced opening of the safes/cabinets, their removal and further new installation of the product and the restoration of the places conditions.